

Fig. 1a

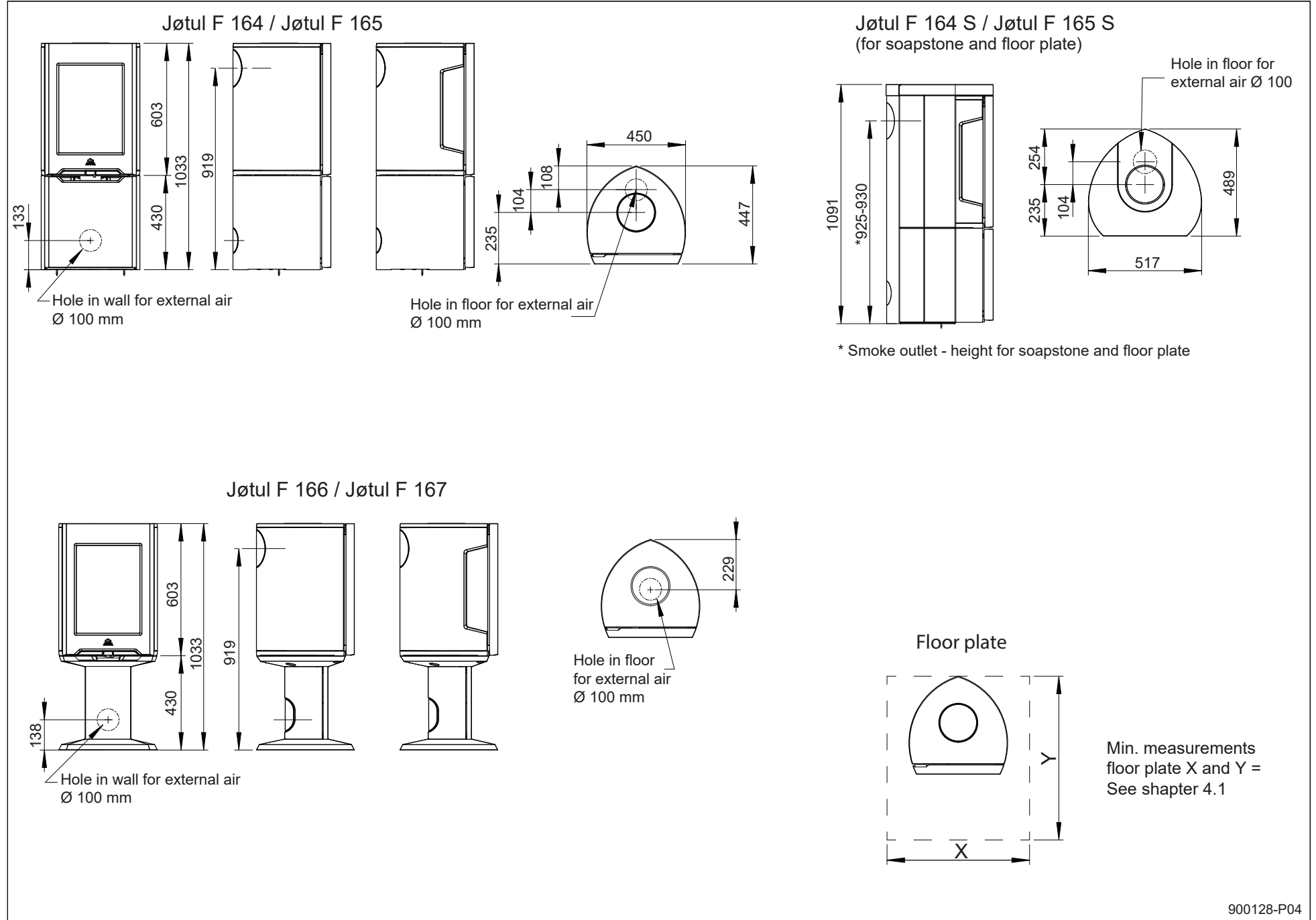
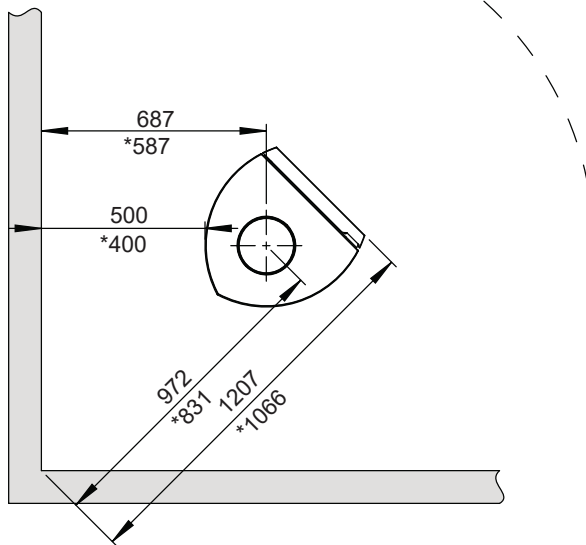
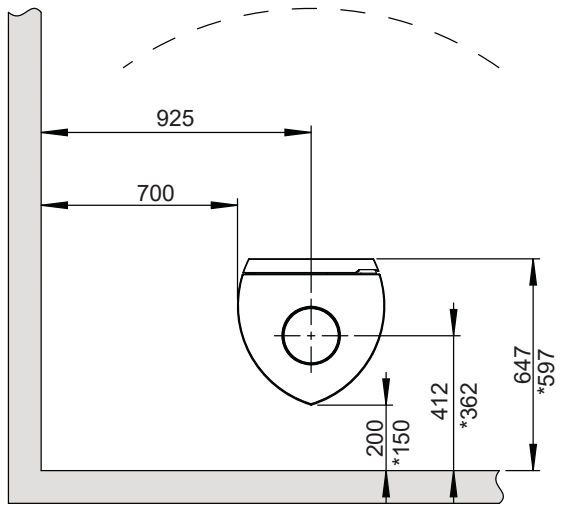

Fig. 1b

Jøtul F 164 / F 165 / F 166 / F 167

Min. distance to combustible wall



* Semi insulated chimney / covered flue pipe down towards the product.

Jøtul F 164 S / F 165 S

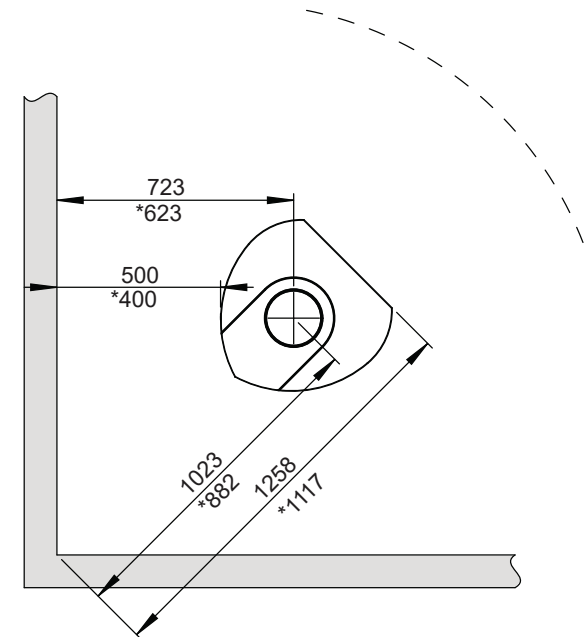
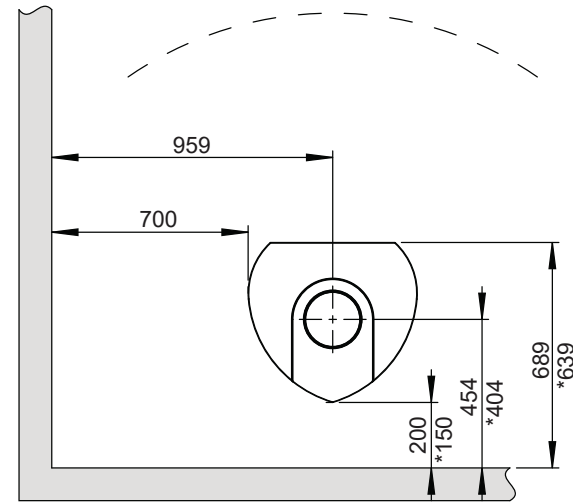
Min. distance to combustible wall.
Soapstone base model

* Semi insulated chimney / covered flue pipe down towards the product.

Fig. 1c

Jøtul F 164 / F 165 / F 166 / F 167

Min. distance to combustibile wall protected by approved firewall:

External

*For Jøtul F 164 S and F 165 S only (Soapstone)

Combustible wall



Firewall

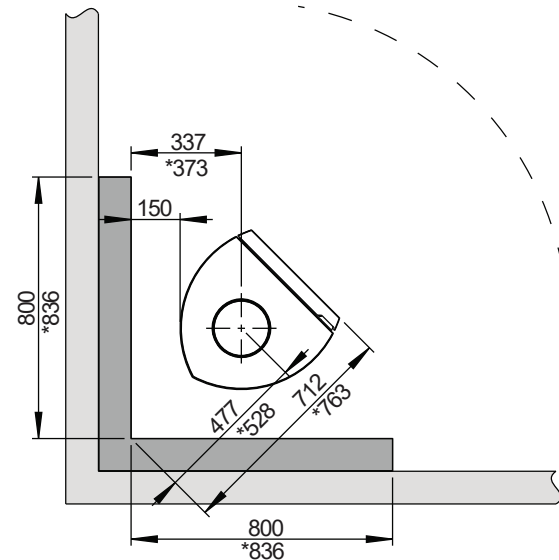
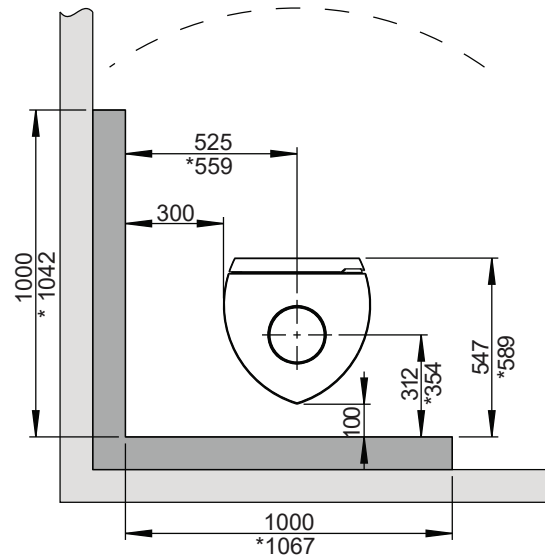
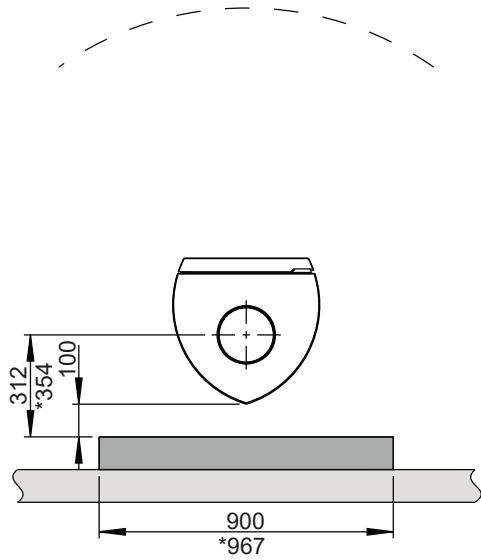

Intergrated

*For Jøtul F 164 S og F 165 S only (Soapstone)

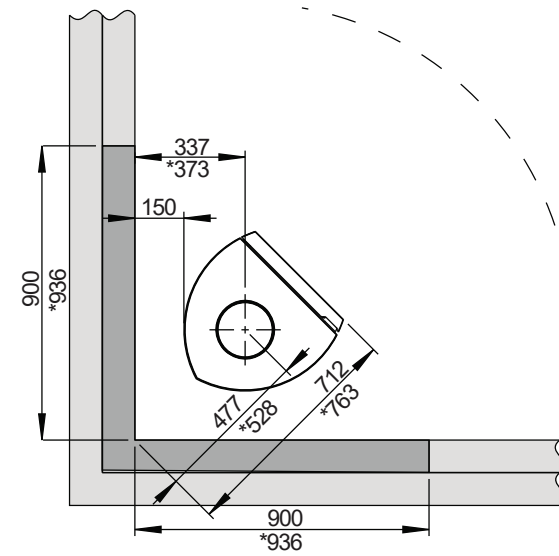
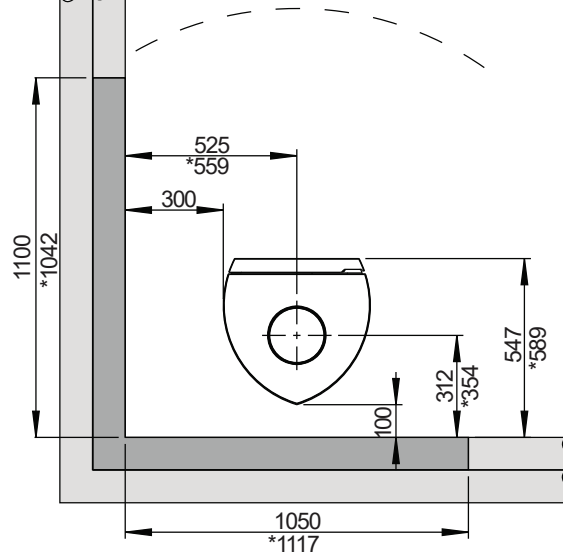
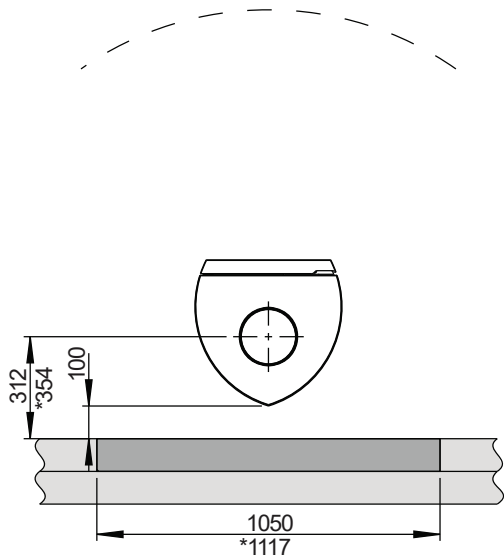

900128-P04