

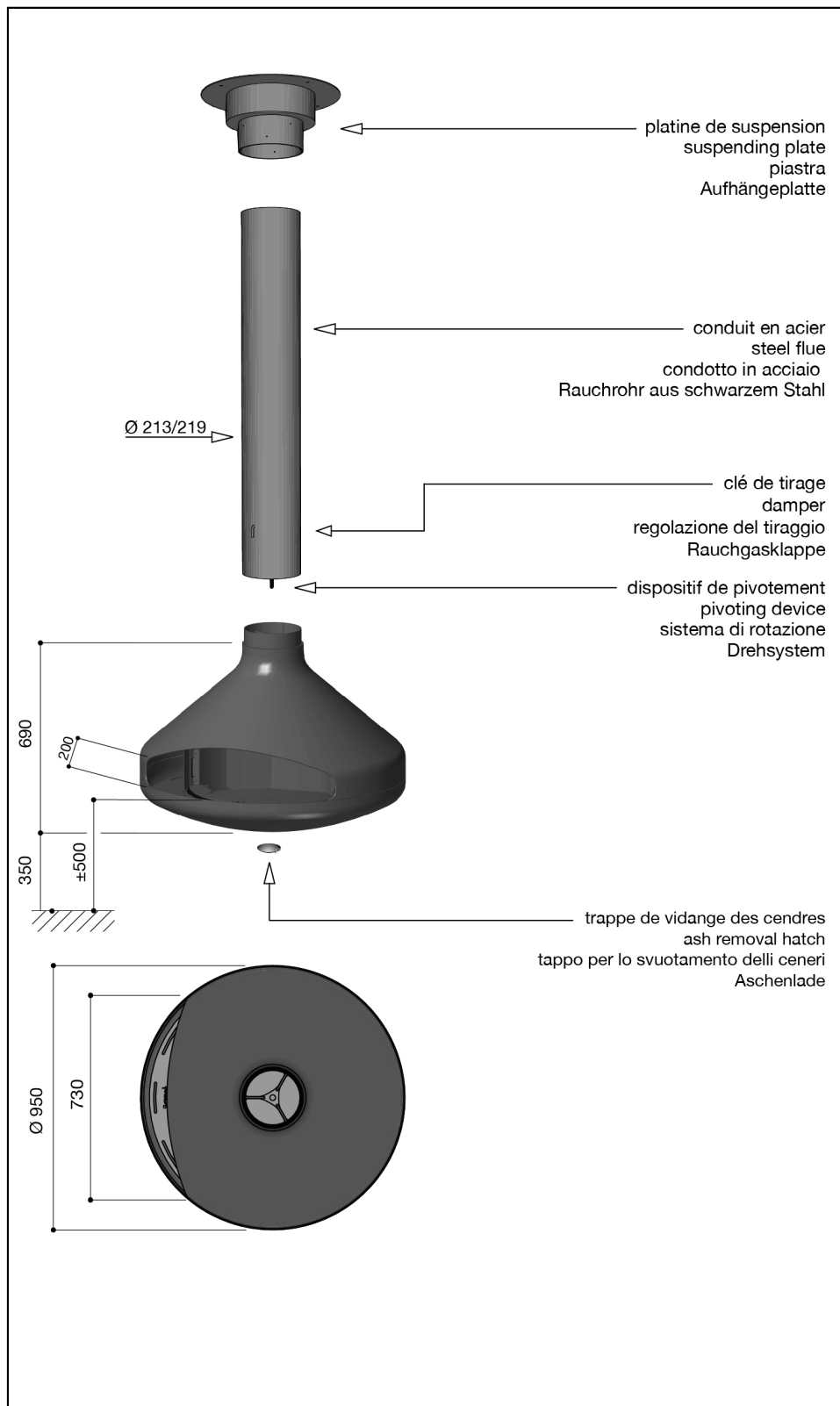

Notice individuelle

Specific instructions
 Istruzione individuale
 Modellspezifische Hinweise
 Individuele instructie
 Instrucción individual
 Дополнительные инструкции
 Supplerende anvisninger
 Täiendavad juhised
 Mallikohtaiset ohjeet
 ατομική κάρτα ενημέρωσης
 További utasítások
 specifiskā instrukcija
 Individuali instrukcija
 Fisa individuala
 Indywidualna instrukcja obsługi
 Noticia individual
 Dodatné inštrukcie
 Dodatna navodila
 Särskilda instruktioner
 Individuální návod
 Struzzjonijiet addizzjonali
 Индивидуална информационна карта



Atelier Dominique Imbert s.a.s
 34380 Viols le fort - France
 téléphone : +33 (0)4 67 55 01 93
 info@focus-creation.com
<http://www.focus-creation.com>

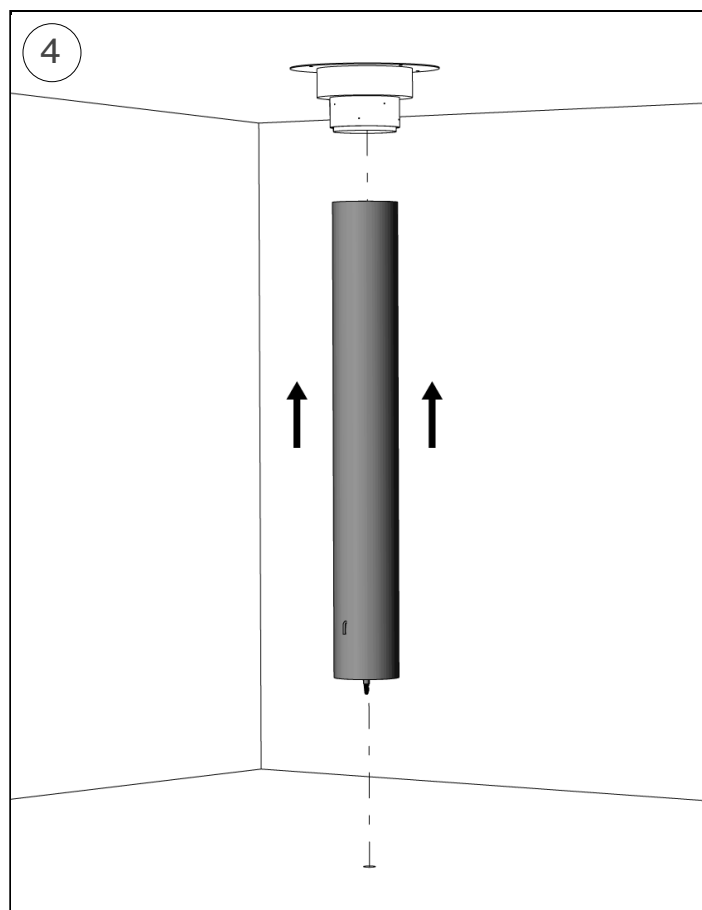
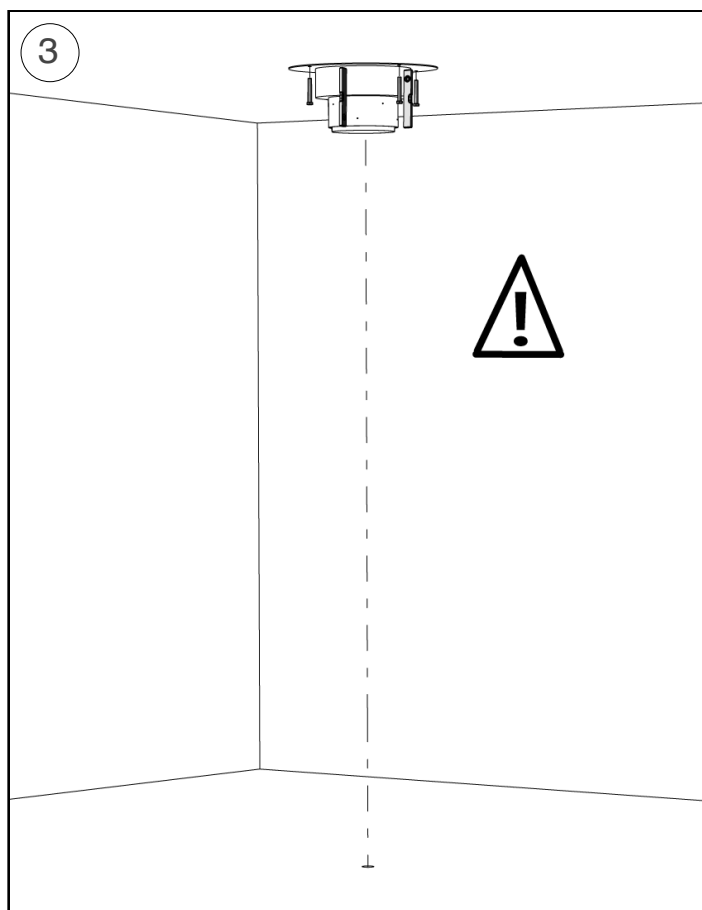
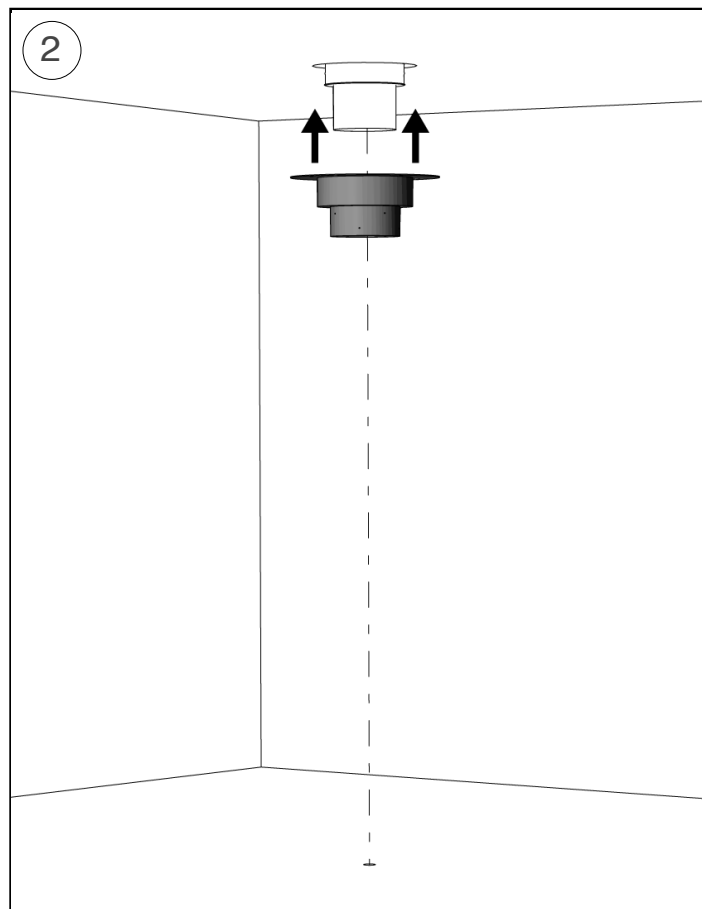
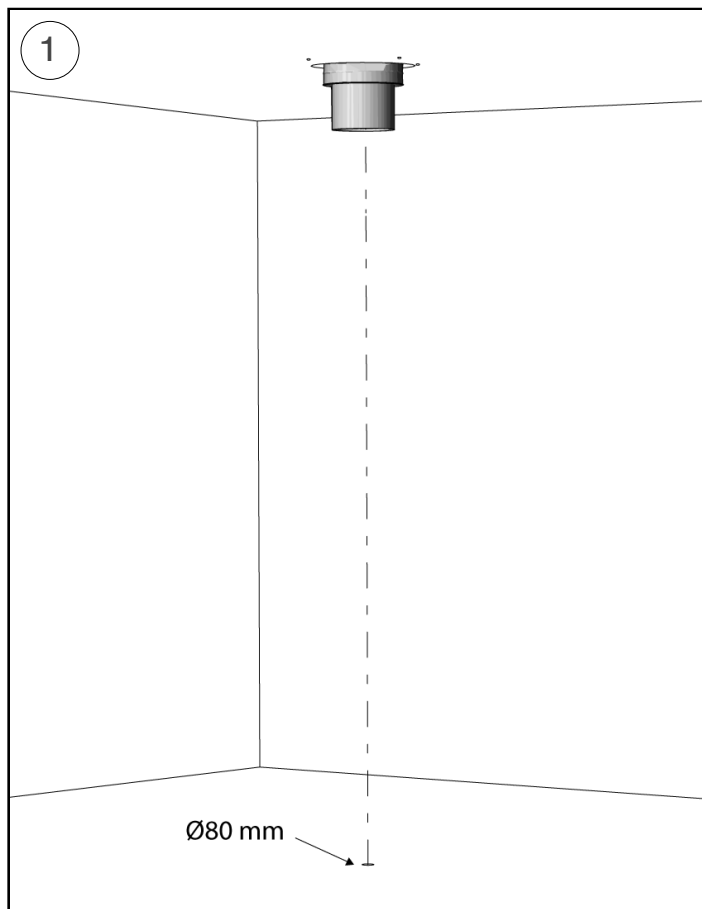

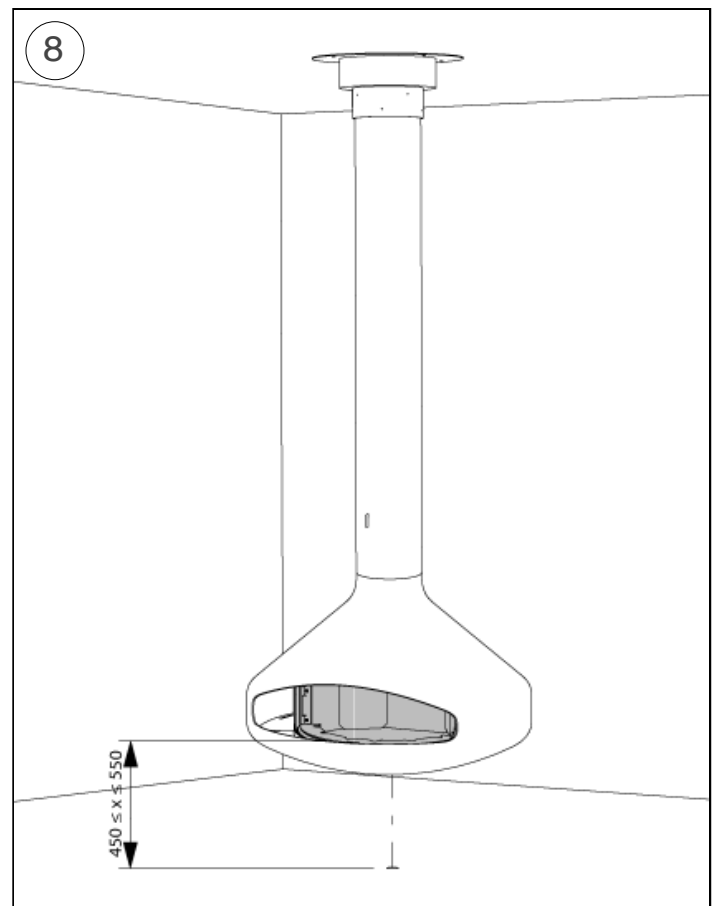
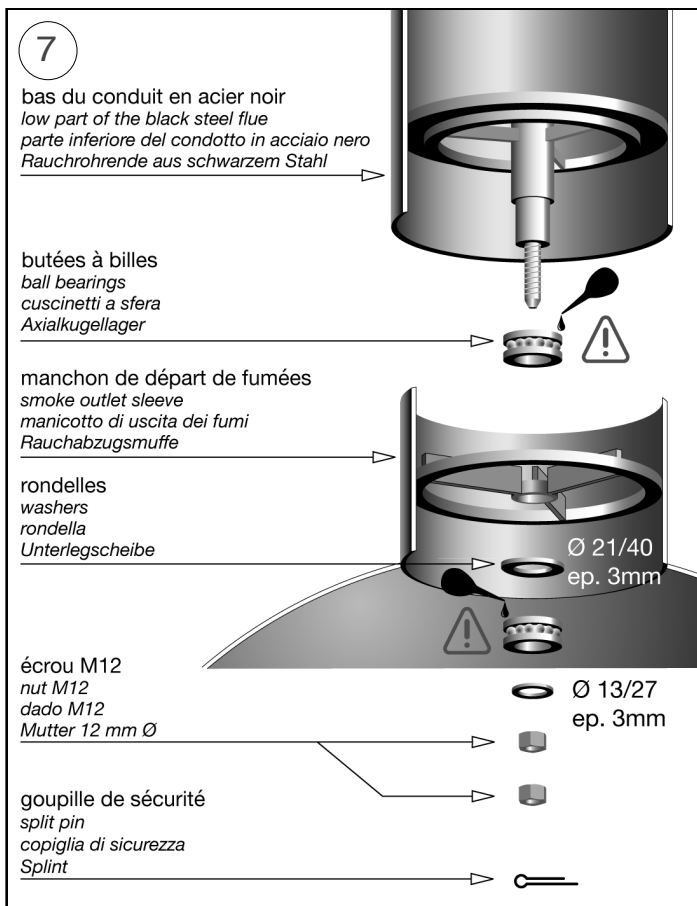
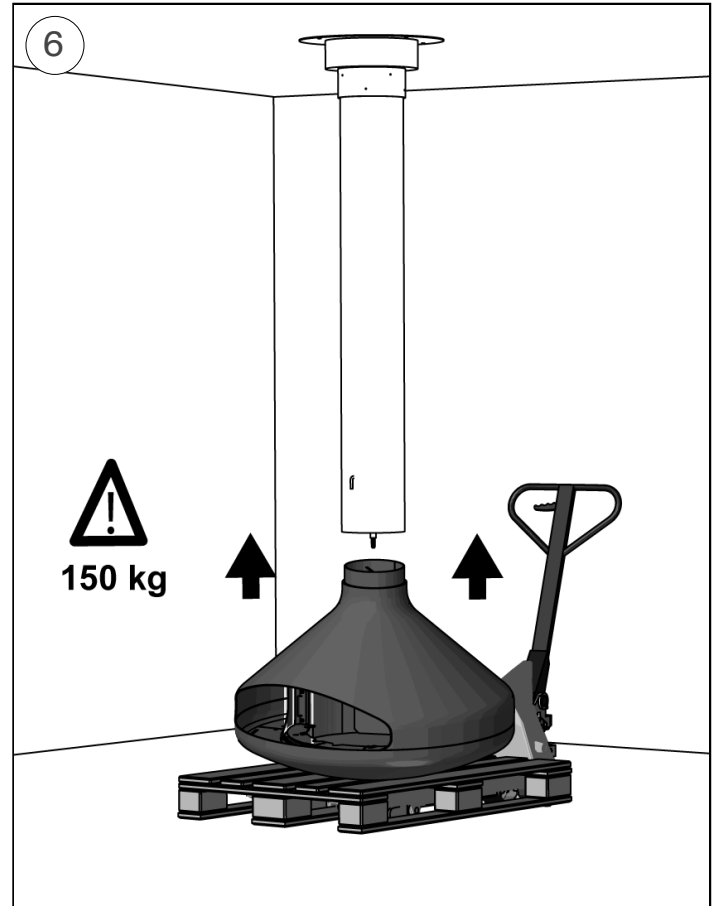
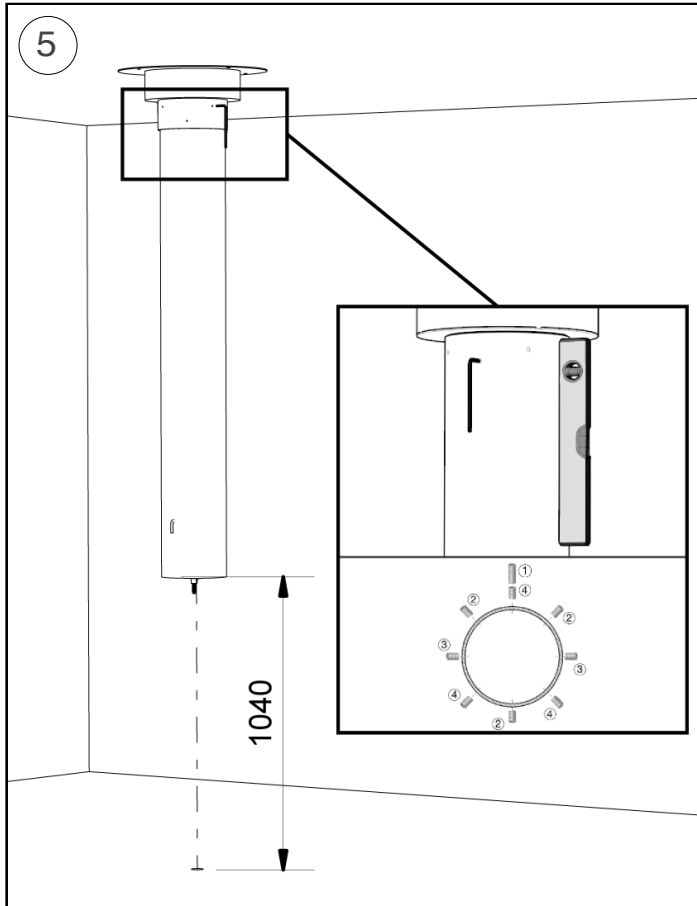

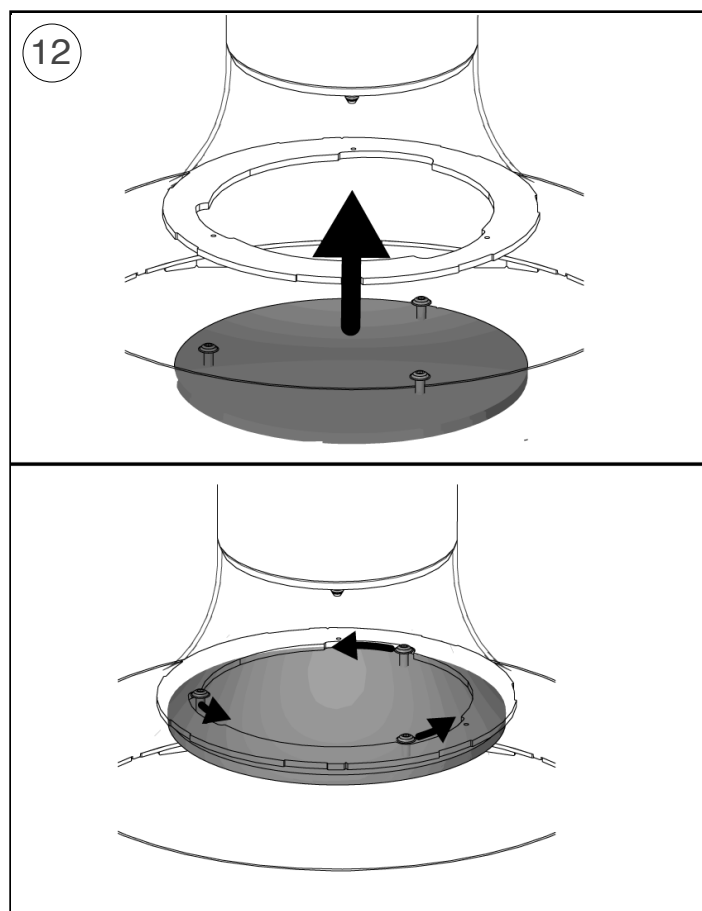
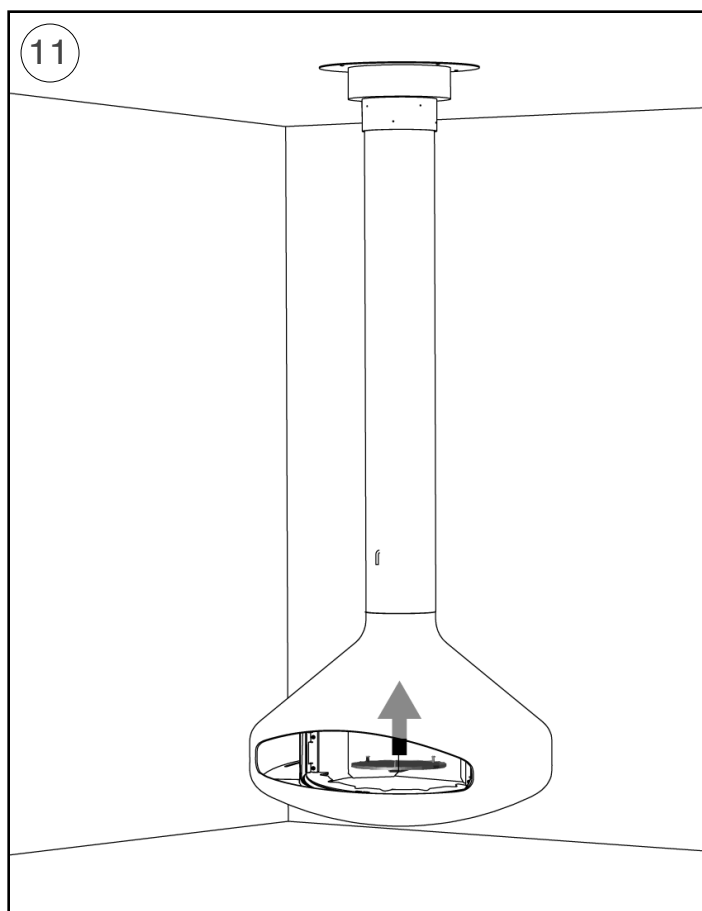
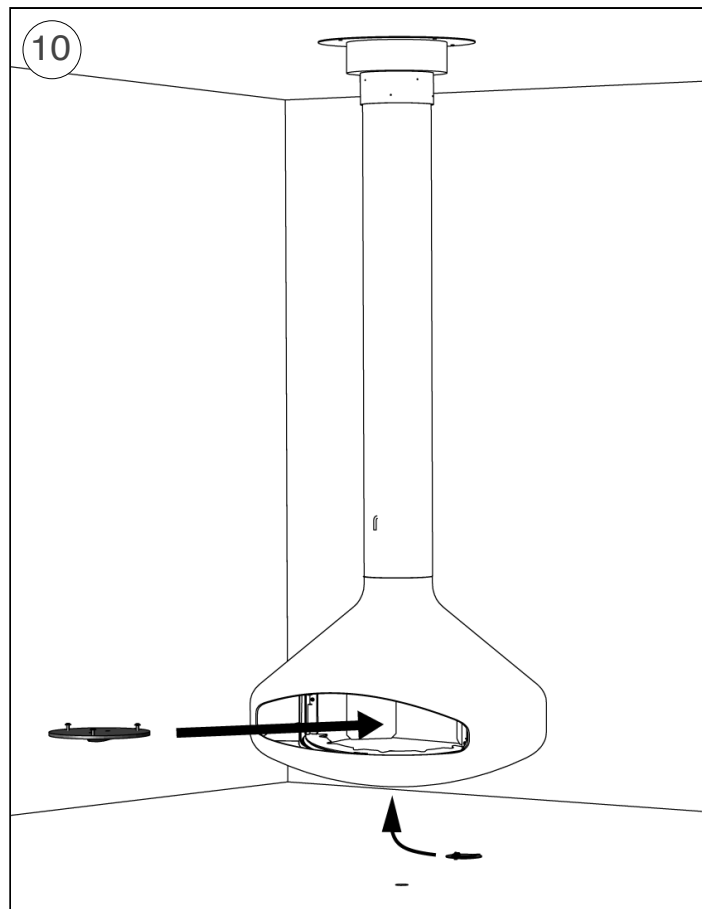
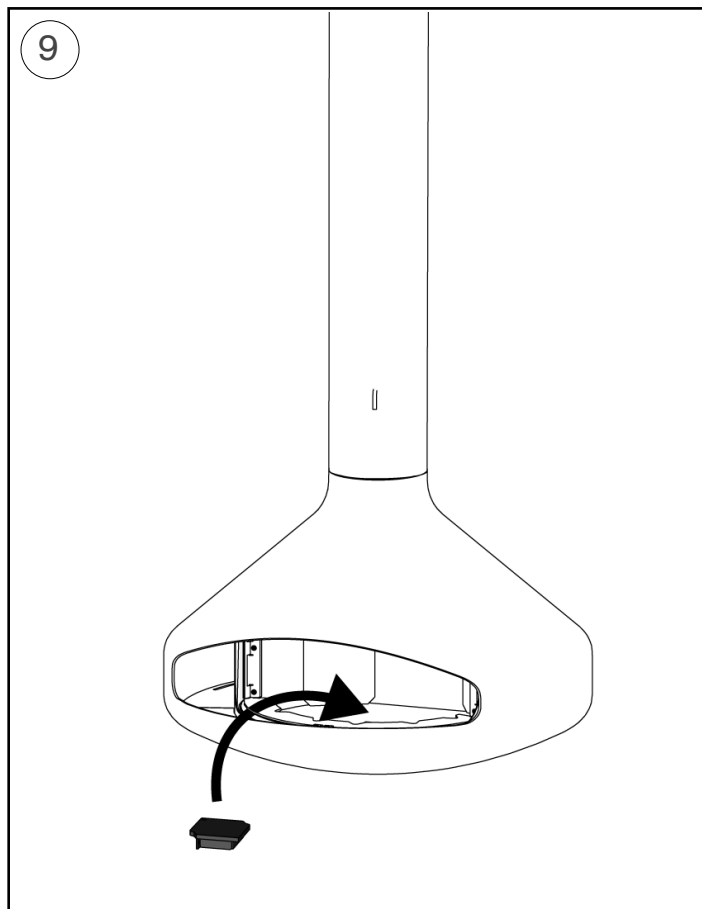

Distances de sécurité par rapport aux matériaux combustibles.

Safety clearance distances from combustible materials.

Mindestabstand hinsichtlich der brennbaren Materialien.

Distanze di sicurezza da ogni materiale combustibile.

distancias de seguridad con relación a los materiales combustibles

Veilige afstand tot brandbaar materiaal.

Sikkerheds afstand til brændbart materiale.

OHUTU KAUGUS
PÕLEVmaterjalidest.

Suojaetäisyydet palava-aineiseen materiaalin.

αποστάσεις ασφαλείας από εύφλεκτα υλικά.

Biztonsági távolság gyúlékony anyagoktól.

Droša distance no viegli uzliesmojošiem materiāliem.

Leistinas saugus atstumas nuo degių medžiagų.

Distanzi li jridu jithallew minn kull materjal li jista jaqbad.

Minimalne odległości bezpieczeństwa od materiałów palnych.

Distâncias de segurança em relação aos materiais combustíveis.

Bezpečnostná vzdialenosť od horľavých materiálov.

Varnostna razdalja glede na vnetljive materiale.

Säkerhetsavstånd från brännbart material.

Bezpečnostní vzdálenost od hořlavých materiálů.

